

werkbreedte  
largeur de travail  
working width  
Arbeitsbreite

A	B	C
1750	1880	2725
2000	2130	2975
2200	2330	3175
2500	2630	3475
3000	3130	3975
3300	3430	4275

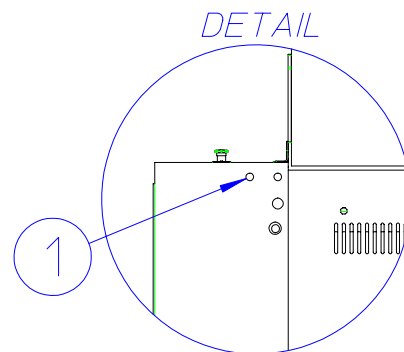

<b>D600 E</b>		<b>052.700.0011A</b>
<b>Rolsnelheid</b> <b>Vitesse repassage</b>	1.5 – 6.5m/min *14m/min	<b>Mangelgeschwindigkeit</b> <b>Ironing speed</b>
<b>Rol aandrijfmotor</b> <b>Moteur entrainement</b>	1.5kw – 1500 rpm *2.2kw – 1500 rpm	<b>Walzenantriebmotor</b> <b>Roll drive motor</b>
<b>Rol afzuigmotor</b> <b>Moteur aspiration</b>	0.75kw – 3000 rpm	<b>Absaugmotor</b> <b>Exhaust motor</b>
<b>Motor circulatiepomp</b> <b>Motor pompe de circ.</b>	2.2kw – 3000 rpm	<b>Umwalzpumpenmotor</b> <b>Circulation pump motor</b>
<b>Motor hydr. pomp</b> <b>Moter pompe hydr.</b>	0.37kw – 1500 rpm	<b>Motor hydr. Pumpe</b> <b>Moter hydr. pump</b>
<b>Verwarming</b> <b>Chauffage</b>	D600/1750 : 45kW D600/2000 : 45kW D600/2200 : 45kW D600/2500 : 50kW D600/3000 : 60kW D600/3300 : 75kW	<b>Heizung</b> <b>Heating</b>

<b>1</b>	<b>Elektrische aansluiting</b> <b>Connection électrique</b> <b>Strom Anschluss</b> <b>Electrical connection</b>	<b>1750/2000/2200/2500</b> <b>230V : 3 x 50mm<sup>2</sup> + PE</b> <b>(150A)</b> <b>3000</b> <b>230V : 3 x 70mm<sup>2</sup> + PE</b> <b>(180A)</b> <b>3300</b> <b>230V : 3 x 95mm<sup>2</sup> + PE</b> <b>(250A)</b>  <b>1750/2000/2200/2500</b> <b>400V : 3 x 16mm<sup>2</sup> + N + PE</b> <b>(80A)</b> <b>3000</b> <b>400V : 3 x 25mm<sup>2</sup> + N + PE</b> <b>(100A)</b> <b>3300</b> <b>400V : 3 x 32mm<sup>2</sup> + N + PE</b> <b>(125A)</b>
<b>2</b>	<b>Afzuiging dampen</b> <b>Sortie buées</b> <b>Wrasenausgang</b> <b>Vapour outlet</b>	<b>Ø125</b>